

# **WGBenjey** *Cylinders*

Formerly DE-STA-CO Cylinders

**MMAC-100**

**MMHC-105**

**A80 SERIES PNEUMATIC  
H80 SERIES HYDRAULIC**

**CONFORMING TO  
CHRYSLER  
CORPORATION STANDARDS**

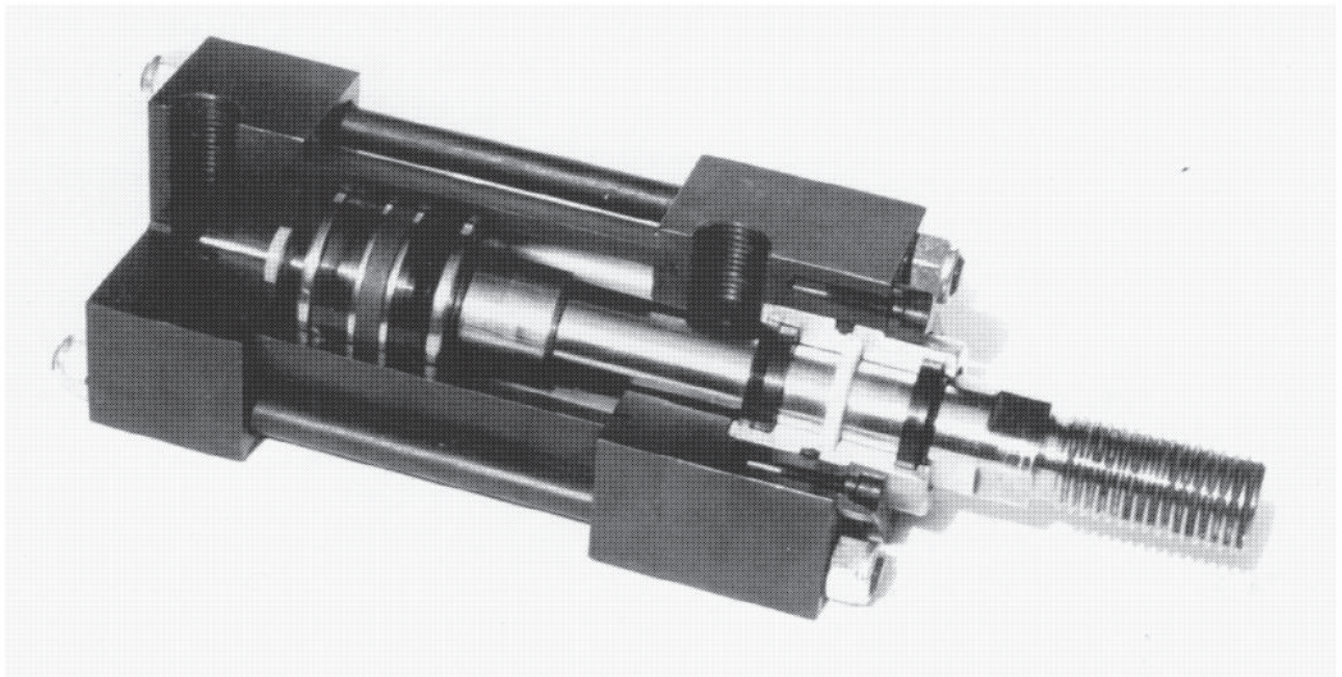

**(Pre-Lubed)**

**2293 Werth Road, Alpena, MI 49707**

**Phone: 800-942-2957 (WGB-CYLS) Fax: 866-942-3297**

**E-Mail: [wgbcylinders@benjey.com](mailto:wgbcylinders@benjey.com)**



# MMAC-100 A80 H80 Series MMHC-105 Basic Dimensions

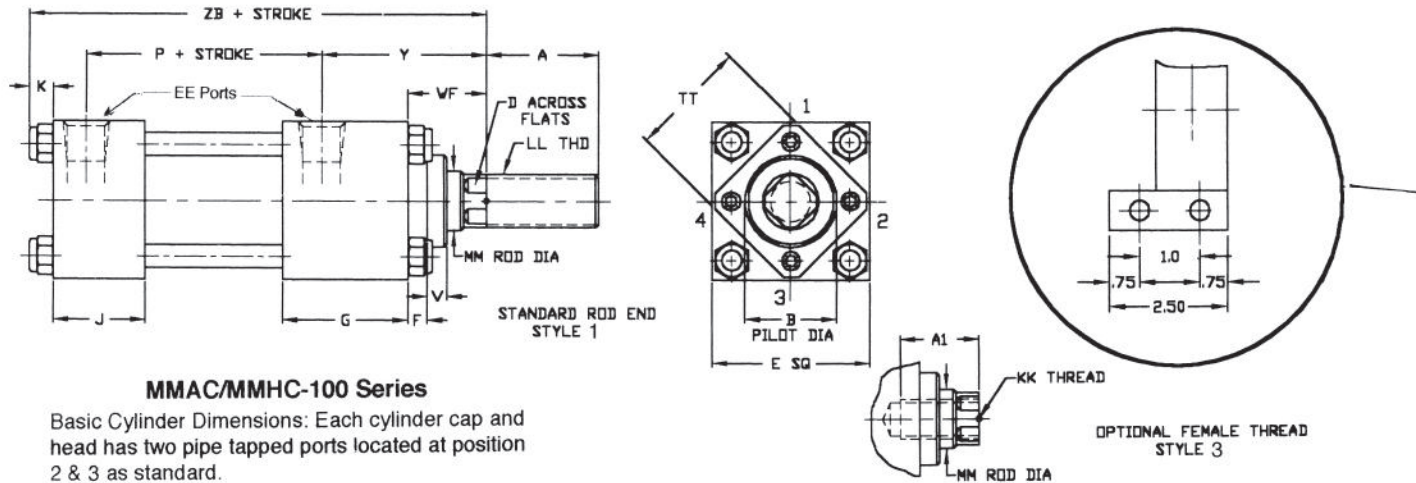

## MMAC/MMHC-100 Series

Basic Cylinder Dimensions: Each cylinder cap and head has two pipe tapped ports located at position 2 & 3 as standard.

### OPTIONAL FEMALE THREAD

### ROD END DIMENSIONS

BORE	E	F	G	J	K	P	V	Y	EE	TT	LB	WF	ZB	A	A <sub>1</sub>	B	D	KK	LL	MM
1-1/2	2-1/2	3/8	2-3/16	1-3/4	1/2	3-7/16	3/8	2-7/8	1/2	1-3/4	5-7/8	1-7/16	7-7/16	1-5/8	7/8	1-3/8	3/4	7/16-20	3/4-10	7/8
2	3	3/8	2-3/8	1-3/4	1/2	3-1/2	3/8	3-1/8	1/2	2-1/4	6-1/8	1-1/2	7-3/4	2-1/8	1-1/2	1-3/4	1	3/4-16	1-8	1-1/8
2-1/2	3-1/2	5/8	2-3/8	1-5/8	5/8	3-9/16	3/8	3-5/16	1/2	2-3/4	6-3/8	1-3/4	8-1/8	2-5/8	2	2 1/8	1-1/4	1-14	1-1/4-12	1-3/8
3-1/4	4-1/2	5/8	2-3/8	2-1/8	13/16	3-7/8	3/8	3-1/4	1/2	2-3/4	6-3/4	1-3/4	8-13/16	2-5/8	2	2-1/8	1-1/4	1-14	1-1/4-12	1-3/8
4	5	5/8	2-3/8	1-3/4	13/16	4-1/16	3/8	3-1/2	3/4	3-1/2	6-7/8	2	9-1/16	3-1/8	2-1/2	2-1/2	1-1/2	1-1/4-12	1-1/2-12	1-5/8
4-1/2	5-1/2	5/8	2-3/8	1-3/4	13/16	4-1/16	3/8	3-1/2	3/4	3-1/2	6-7/8	2	9-1/16	3-1/8	2-1/2	2-1/2	1-1/2	1-1/4-12	1-1/2-12	1-5/8
5	6	3/4	2-15/16	1-13/16	15/16	4-3/4	3/8	4-7/16	3/4	4	8-1/4	2-3/8	10-13/16	4-1/8	3	3	2	1-1/2-12	2-12	2-1/8
6	7	3/4	2-15/16	1-13/16	15/16	4-3/4	3/8	4-7/16	3/4	4	8-1/4	2-3/8	10-13/16	4-1/8	3	3	2	1-1/2-12	2-12	2-1/8
8	9-1/2	1	3-7/8	2-3/16	15/16	6-7/8	3/8	5-9/16	1	5	11-1/2	2-3/4	14-3/16	5-5/8	4	4	2-3/4	2-1/4-12	2-3/4-12	3

## MODEL DESCRIPTION

### AIR AND HYDRAULIC CYLINDERS

Series MMAC ---100 Air  
Series MMHC --- 100 Hyd.  
Heavy Duty cylinders are intended for use on heavy duty conditions.  
Maximum Pressure: 200 PSIG Air and 1000 PSIG Hydraulic.  
Cylinder Number System

#### MMAC --- 100 --- Rod End

- 1 = Std. long male
- 3 = Short female

#### Operating Media and Seals

- 0 = Compressed Air
- 5 = Non-Metallic Seals for use with Water Emulsion Fluids and Oil Base Hydraulic Fluids.
- 6 = Seals and Automotive Type Piston Rings for use with Water Emulsion Fluids and Oil Base Hydraulic Fluids.
- 7 = Non-Metallic Seals for use with Phosphate Ester Fluids.
- 8 = Seals and Automotive Type Piston Rings for use with Phosphate Ester Fluids.

#### Mount

- 0 = Foot Mount
- 1 = Rear Flange Mount
- 2 = Front Flange Mount
- 3 = Clevis Mount
- 4 = Trunnion --- Front & Center
- 5 = Sub Plate
- 6 = Trunnion --- Rear

#### Series

- 1 - 100 Series Heavy Duty Cylinders
- C = Cylinder
- A = Air
- H = Hydraulic

### WHEN ORDERING SPECIFY AS FOLLOWS:

1. Quantity Required
2. Model Number
3. BR --- For Cushioned Both Ends or N --- For Non-Cushioned
4. Bore Size
5. Stroke (available in one inch increments only)
6. Port Location --- When other than ports 2 and 3 are required (optional ports are 1 and 4)

Example: 4 Req. MMAC-100-BR-4 x 5

\* CYLINDERS WITH 1 AND 2 STROKES ARE NON-CUSHIONED.  
CYLINDERS OVER 2" STROKE ARE CUSHIONED BOTH ENDS.  
\* FOR LARGER BORE SIZES SEE D.C.1 STANDARD CATALOGS.

MOUNT	CHRYSLER MODEL #'s	
	AIR	HYDRAULIC
Foot Mount	MMAC-100	MMHC-105
Rear Flange Mount	MMAC-110	MMHC-115
Front Flange Mount	MMAC-120	MMHC-125
Clevis Mount	MMAC-130	MMHC-135
Trunnion --- Front & Center	MMAC-140	MMHC-145

# MMAC-100 A80 H80 Series MMHC-105 MOUNTINGS

**FOOT MOUNT** MMAC-100  
MMHC-105

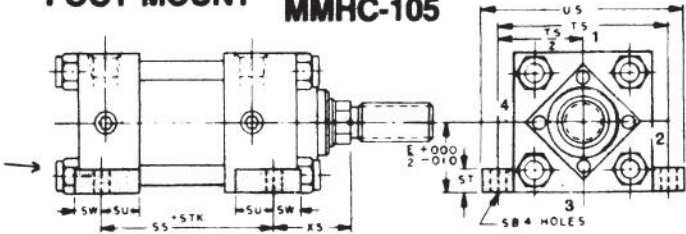

BORE	1 1/2	2	2 1/2	3 1/4	4	4 1/2	5	6	8
SW	3/4	3/4	1	1	1	1	1 1/4	1 1/4	1 1/2
SS	4 1/4	4 1/2	4 3/4	5	5	5	6	6	6 3/4
TS	3 1/2	4	4 3/4	5 1/2	6 1/4	7	7 1/2	8 1/2	11 1/4
US	4 1/4	4 3/4	5 3/4	6 1/2	7 1/2	8 1/4	9	10	13 1/4
XS	2 1/16	2 1/8	2 3/8	2 3/8	2 3/8	2 3/8	3 1/8	3 1/8	5 1/4
SU	3/4	3/4	1	1	1	1	1 1/4	1 1/4	1 1/2
ST	1/2	1/2	5/8	7/8	7/8	7/8	1	1	1 1/8
SB	1 3/32	1 3/32	1 7/32	1 7/32	2 1/32	2 1/32	2 5/32	2 5/32	1 1/32

**FRONT FLANGE MOUNT** MMAC-120  
MMHC-125

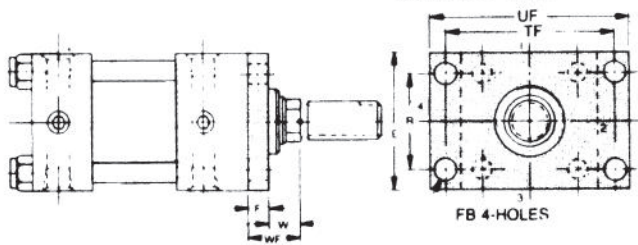

BORE	1 1/2	2	2 1/2	3 1/4	4	4 1/2	5	6	8
E	2 1/2	3	3 1/2	4 1/2	5	5 1/2	6	7	9 1/2
F	3/8	3/8	5/8	5/8	5/8	5/8	3/4	3/4	1
R	1 1/2	2	2 1/2	3	3 1/2	4	4 1/2	5 1/2	7
W	1 1/16	1 1/8	1 1/8	1 1/8	1 3/8	1 3/8	1 5/8	1 5/8	1 3/4
FB	1 3/32	1 3/32	1 7/32	1 7/32	2 1/32	2 1/32	2 5/32	2 5/32	1 1/32
TF	3 1/2	4	4 3/4	5 1/2	6 1/4	7	7 1/2	8 1/2	11 1/4
UF	4 1/4	4 3/4	5 3/4	6 1/2	7 1/2	8 1/4	9	10	13 1/4
WF	1 1/16	1 1/2	1 3/4	1 3/4	2	2	2 3/8	2 3/8	2 3/4

**REAR FLANGE MOUNT** MMAC-110  
MMHC-115

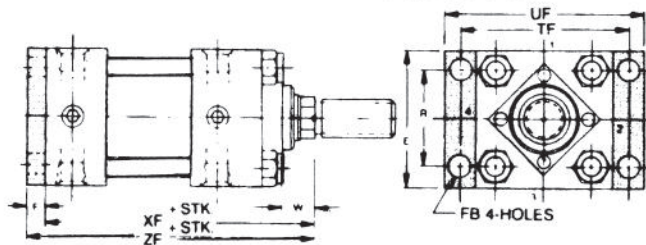

BORE	1 1/2	2	2 1/2	3 1/4	4	4 1/2	5	6	8
E	2 1/2	3	3 1/2	4 1/2	5	5 1/2	6	7	9 1/2
F	3/8	3/8	5/8	5/8	5/8	5/8	3/4	3/4	1
R	1 1/2	2	2 1/2	3	3 1/2	4	4 1/2	5 1/2	7
W	1 1/16	1 1/8	1 1/8	1 1/8	1 3/8	1 3/8	1 5/8	1 5/8	1 3/4
FB	1 3/32	1 3/32	1 7/32	1 7/32	2 1/32	2 1/32	2 5/32	2 5/32	1 1/32
TF	3 1/2	4	4 3/4	5 1/2	6 1/4	7	7 1/2	8 1/2	11 1/4
UF	4 1/4	4 3/4	5 3/4	6 1/2	7 1/2	8 1/4	9	10	13 1/4
XF	6 5/16	7 1/4	7 1/2	8	8 1/4	8 1/4	9 7/8	9 7/8	13 1/4
ZF	7 9/16	7 5/8	8 1/8	8 1/2	8 7/8	8 7/8	10 5/8	10 5/8	14 1/4

**CLEVIS MOUNT** MMAC-130  
MMHC-135

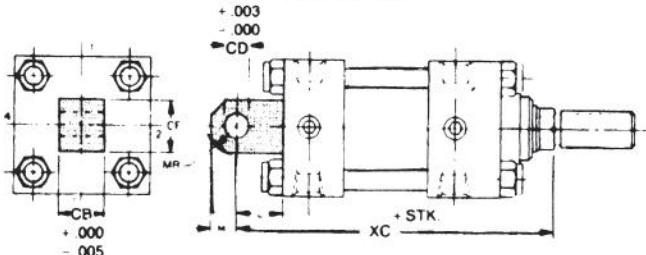

BORE	1 1/2	2	2 1/2	3 1/4	4	4 1/2	5	6	8
L	1 1/4	1 1/4	1 3/8	1 1/2	1 7/8	1 7/8	2 1/4	2 1/4	3
M	3/4	3/4	7/8	7/8	1 1/8	1 1/8	1 1/2	1 1/2	2
CB	1	1	1 1/2	1 1/2	2	2	2 1/2	2 1/2	3
CD	5/8	5/8	3/4	3/4	1	1	1 1/2	1 1/2	2
CE	1 1/2	1 1/2	1 3/4	1 3/4	2 1/4	2 1/4	3	3	4
MR	2 7/32	2 7/32	1 5/16	1 5/16	1 1/4	1 1/4	1 5/8	1 5/8	2 1/4
XC	8 3/16	8 1/2	8 5/8	9 3/8	10 1/8	10 1/8	12 1/8	12 1/8	16 1/4

**TRUNNION — CENTER** MMAC-140  
MMHC-145

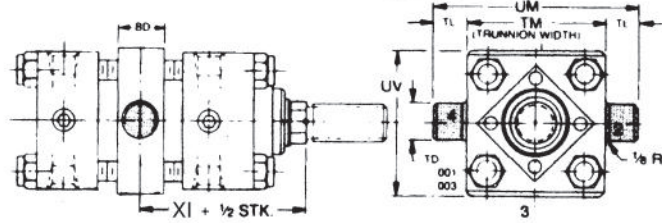

BORE	1 1/2	2	2 1/2	3 1/4	4	4 1/2	5	6	8
BD	1 1/2	1 1/2	1 1/2	1 1/2	2	2	2	2	2 1/2
UM	4 1/2	5	5 1/2	6 1/2	8 1/2	9	10	11	15
TM	2 1/2	3	3 1/2	4 1/2	5 3/4	6 1/4	7 1/4	8 1/4	11 1/2
TL	1	1	1	1	1 3/8	1 3/8	1 3/8	1 3/8	1 3/4
UV	2 3/4	3 1/4	3 3/4	4 1/2	5 3/4	6 1/4	7 1/4	8 1/4	11 1/2
TD	1	1	1	1	1 1/2	1 1/2	1 1/2	1 1/2	2
XI	4 9/16	4 7/8	5 1/8	5 1/8	5 5/8	5 5/8	6 3/8	6 3/8	9

Standard port location is position 2 and 3. Each head has 2-ports.

### ROD EYE Internal Thread

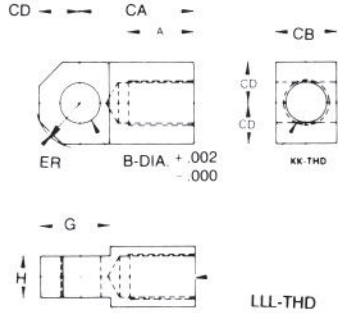

BORE	PART NO.	ROD	A	B	G	H	CA	CB	CD	ER	LL
1½	IE801	7/8	15/16	5/8	15/8	1	2¼	1/8	3/4	51/64	¾-10
2	IE802	1 1/8	15/16	5/8	15/8	1	2 5/8	1/2	¾	51/64	1-8
2½-3¼	IE803	1 3/8	1 1/8	¾	1 15/16	1 1/2	3	1 3/4	7/8	61/64	1 1/4-12
4-4½	IE804	1 5/8	1 7/8	1	2 1/2	2	3 1/2	2 1/4	1 1/8	1 19/64	1 1/2-12
5-6	IE805	2 1/8	2 5/8	1 1/2	3 1/4	2 1/2	4 5/8	3	1 1/2	1 13/16	2-12
8	IE806	3	3 1/2	2	4 1/2	3	6 1/2	4	2	2 1/2	2 3/4-12

### ROD CLEVIS Internal Thread

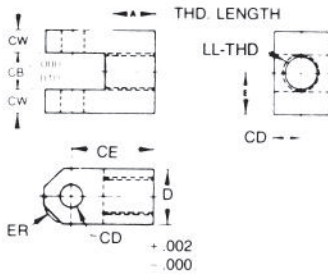

BORE	PART NO.	ROD	A	D	E	CB	CD	CE	CW	ER	LL
1½	IC801	7/8	15/16	1/4	1 1/8	1.005	.626	2 5/8	5/8	51/64	¾-10
2	IC802	1 1/8	15/16	1/4	1 1/8	1.005	.626	2 3/4	5/8	51/64	1-8
2½-3¼	IC803	1 3/8	1 1/8	1 1/2	1 1/2	1.505	.751	3 3/8	¾	61/64	1 1/4-12
4-4½	IC804	1 5/8	1 7/8	2	2	2.005	1.001	3 5/8	1	1 19/64	1 1/2-12
5-6	IC805	2 1/8	2 5/8	3	2 1/2	2.505	1.501	4 5/8	1 1/4	1 13/16	2-12
8	IC806	3	3 1/2	4	3	3.005	2.001	6 1/2	1 1/2	2 1/2	2 3/4-12

### CLEVIS BRACKET

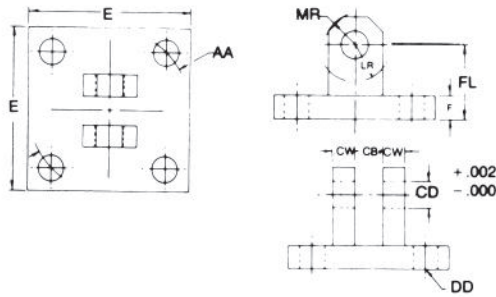

BORE	PART NO.	ROD	E	F	AA	CB	CD	CW	DD	FL	LR	MR
1½	CB801	7/8	3 1/2	5/8	3 23/32	1.005	.626	5/8	1 5/32	1 7/8	1	51/64
2	CB802	1 1/8	3 1/2	5/8	3 23/32	1.005	.626	5/8	1 5/32	1 7/8	1	51/64
2½-3¼	CB803	1 3/8	4 1/2	3/4	4 25/32	1.505	.751	3/4	1 1/16	2 1/8	1 1/8	61/64
4-4½	CB804	1 5/8	5 1/2	3/4	6 3/16	2.005	1.001	1	1 1/16	2 1/2	1 7/16	1 19/64
5-6	CB805	2 1/8	7	1	7 25/32	2.505	1.501	1 1/4	1 9/16	3 3/4	1 1/8	1 13/16
8	CB806	3	9 1/4	1	11 3/16	3.005	2.001	1 1/2	1 3/16	4 1/8	2 5/8	2 1/2

### PIVOT PIN

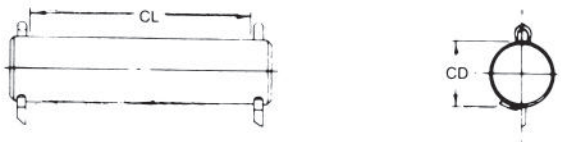

Part Number	Dimensions	
	CD	CL
P801	.625	2.37
P802	.750	3.12
P803	1.000	4.12
P804	1.375	4.12
P805	1.500	5.12
P806	1.750	5.12
P807	2.000	5.12
P808	2.000	6.12
P809	2.500	6.12
P810	3.000	6.12
P811	3.500	8.12



# MMAC-100 A80 H80 Series MMHC-105 Design Features

## MMAC/MMHC-100

**The bearing retainer** is held in place by cap screws and the bearing cartridge assembly is easily removed without disturbing the tie rods on all mounts except the rod end flange.

**The bearing cartridge** is extra long for high cycle usage in automation equipment. This bearing is close tolerance machined from 660 bearing bronze, fitted with self compensating rod wiper, rod packings and bearing O-ring. Bearing wick to insure even distribution of lubricant.

**All male rod threads** have four wrench flats furnished as standard.

**The piston rods** are 100,000 PSI minimum tensile steel, ground, polished and hard chrome plated to a 15 RMS finish or better.

**Cushion adjustment** screws and ball checks are both interchangeable and flush to the head and cap.

**Cushions for deceleration** are supplied as an option and do not change mounting or overall dimension of the cylinder.

**Piston wear band:** Delrin band insures no metal-to-metal contact.

**Piston is one piece** fine grained grey iron machined with long thread engagement with the piston rod to provide better shock absorption. The piston is longer than the average cylinder to provide additional bearing surface for long life.

**Heads and caps** are cold rolled steel machined to provide concentricity for mating components.

**Cylinder tube** is 1015 through 1020 steel honed and hard chrome plated on the ID to a 15 micro inch finish or better.

**The piston cups** are self compensating dynamic seals of Buna N that adjust for pressure variations and wear. Other compounds can be supplied for an additional charge.

**O-rings are used** for static seals at the tube, bearing, ball check, cushion adjustment and rod end cushion.

**N.P.T.F. ports** are standard for both air and hydraulic usage. SAE O-ring ports can be supplied for hydraulic application at no additional charge.

**Tie rods** are made from 100,000 PSI minimum tensile steel.

\* **NO ADDITIONAL LUBRICATION NEEDED ( NON-LUBE SERVICE)**



# MMAC-100 A80 H80 Series MMHC-105 PARTS LIST

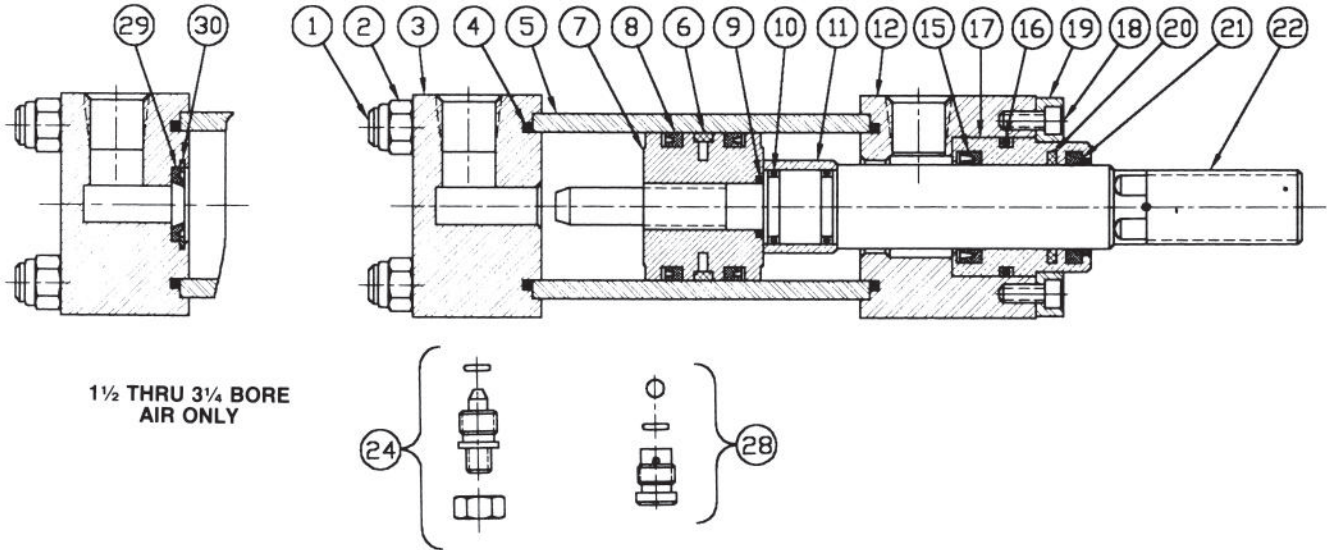

1 1/2 THRU 3 1/4 BORE  
AIR ONLY

- |    |                  |    |                           |
|----|------------------|----|---------------------------|
| 1  | TIE ROD          | 15 | ROD PACKING               |
| 2  | TIE ROD NUT      | 16 | BEARING O.D. SEAL SET     |
| 3  | CAP              | 17 | BEARING CARTRIDGE         |
| 4  | TUBE SEAL SET    | 18 | RETAINER CAP SCREW        |
| 5  | TUBE             | 19 | RETAINER PLATE            |
| 6  | PISTON WEAR BAND | 20 | CARTRIDGE LUBRICATOR      |
| 7  | PISTON           | 21 | ROD WIPER                 |
| 8  | PISTON CUPS      | 22 | PISTON ROD                |
| 9  | PISTON O-RING    | 24 | ADJUSTMENT SCREW ASSEMBLY |
| 10 | CUSHION O-RING   | 28 | BALL CHECK ASSEMBLY       |
| 11 | ROD CUSHION      | 29 | CAP HEAD SNAP RING        |
| 12 | HEAD             | 30 | CAP HEAD CUSHION SEAL     |

When ordering spare parts, always have the cylinder model description, bore, stroke, rod diameter, serial number and operating media.

## Cylinder Pressure and Force Chart

(Theoretical values do not allow for frictional losses)  
Maximum pneumatic operating pressure is 250 P.S.I.

Cylinder Bore	Rod Diameter	Work Action	OPERATING PRESSURE P.S.I.									
			60	80	90	100	110	120	250	500	750	1000
1 500	875	PUSH	106	141	159	177	194	212	442	884	1326	1767
		PULL	70	93	105	117	128	140	292	583	875	1166
2 000	1 125	PUSH	188	251	283	314	346	377	785	1571	2356	3141
		PULL	129	172	193	215	236	258	537	1074	1610	2147
2 500	1 375	PUSH	294	393	442	491	540	589	1227	2454	3681	4908
		PULL	205	274	308	342	377	411	2929	1712	2567	3423
3 250	1 375	PUSH	489	666	747	830	912	995	2074	4148	6221	8295
		PULL	409	545	613	681	749	817	1703	3405	5108	6810
4 000	1 625	PUSH	754	1005	1130	1257	1382	1508	3142	6283	9425	12566
		PULL	630	839	944	1049	1154	1259	2623	5246	7869	10492
4 500	1 625	PUSH	954	1272	1431	1590	1749	1908	3976	7952	11928	15904
		PULL	830	1106	1245	1383	1521	1660	3458	6915	10373	13830
5 000	2 125	PUSH	1178	1571	1767	1964	2160	2356	4909	9819	14726	19635
		PULL	965	1287	1448	1609	1770	1931	4022	8045	12067	16089
6 000	2 125	PUSH	1696	2262	2545	2827	3110	3392	7096	14137	21206	28274
		PULL	1484	1978	2226	2473	2720	2967	6182	12364	18546	24728
8 000	3 000	PUSH	3016	4021	4524	5027	5529	6032	12566	25133	37689	50265
		PULL	2592	3456	3888	4320	4752	5184	10799	21599	32398	43197



# Ordering Information

## MMAC/MMHC 100E Series Cylinders

**MM   A   C   140   E -   BR   -   2.5   x   3   -   1   (C2)**

**Series**  
MM

**Power**  
A Air  
H Hydraulic

**Extra Rod Extension**  
**C1** Standard Extension  
**C2** 2.00" Extension  
**C3** 3.00" Extension  
**C4** 4.00" Extension  
**C5** 5.00" Extension  
 (See chart below for more information)

**Rod End**  
**1** Standard Long Male  
**3** Optional Short Female

**Stroke**  
Specify Stroke in One Inch Increments

**Bore**  
**1.50** 1.50" Bore    **4.50** 4.50" Bore  
**2.00** 2.00" Bore    **5.00** 5.00" Bore  
**2.50** 2.50" Bore    **6.00** 6.00" Bore  
**3.25** 3.25" Bore    **8.00** 8.00" Bore  
**4.00** 4.00" Bore

**Cushions**  
**BR** Cushioned Both Ends  
**N** Non-Cushioned

Note:  
Port Positions 2 & 3 are standard.  
Other positions are available as a special order.

**Mount**

Description	Order Code		
	NFPA Code	Air 250psi	Hydraulic 1000psi
Foot Mount	MS2	<b>100</b>	<b>105</b>
Rear Flange Mount	MF2	<b>110</b>	<b>115</b>
Front Flange Mount	MF1	<b>120</b>	<b>125</b>
Clevis Mount	MP3	<b>130</b>	<b>135</b>
Trunnion – Front & Center	MT4	<b>140</b>	<b>145</b>

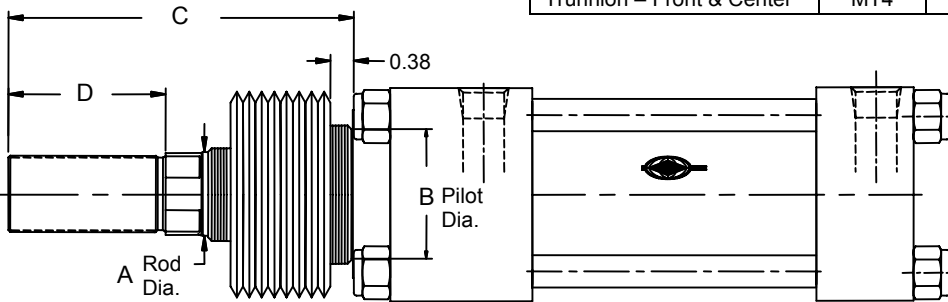

	Cylinder	Extended Rod	Stroke (Inches)
<b>C1</b>	MMAC100	No	N/A
<b>C2</b>	MMAC100E	Yes	1-10
<b>C3</b>	MMAC100E	Yes	11-20
<b>C4</b>	MMAC100E	Yes	21-30
<b>C5</b>	MMAC100E	Yes	31-40

Bore	Boot Part Number (Supplied with 100E Cylinders)				A	B	Std. Extension C1	2.00 Extra Rod Extension C2	3.00 Extra Rod Extension C3	4.00 Extra Rod Extension C4	5.00 Extra Rod Extension* C5	D
	Stroke 1-10	Stroke 11-20	Stroke 21-30	Stroke * 31-40								
1.50	BT-15-1/10	BT-15-11/20	BT-15-21/30	BT-15-31/40	0.875	1.375	2.69	4.69	5.69	6.69	7.69	1.63
2.00	BT-20-1/10	BT-20-11/20	BT-20-21/30	BT-20-31/40	1.125	1.750	3.25	5.25	6.25	7.25	8.25	2.12
2.50	BT-25-1/10	BT-25-11/20	BT-25-21/30	BT-25-31/40	1.375	2.125	3.75	5.75	6.75	7.75	8.75	2.62
3.25	BT-32-1/10	BT-32-11/20	BT-32-21/30	BT-32-31/40	1.375	2.125	3.75	5.75	6.75	7.75	8.75	2.62
4.00	BT-40-1/10	BT-40-11/20	BT-40-21/30	BT-40-31/40	1.625	2.500	4.50	6.50	7.50	8.50	9.50	3.12
4.50	BT-45-1/10	BT-45-11/20	BT-45-21/30	BT-45-31/40	1.625	2.500	4.50	6.50	7.50	8.50	9.50	3.12
5.00	BT-50-1/10	BT-50-11/20	BT-50-21/30	BT-50-31/40	2.125	3.000	5.75	7.75	8.75	9.75	10.75	4.12
6.00	BT-60-1/10	BT-60-11/20	BT-60-21/30	BT-60-31/40	2.125	3.000	5.75	7.75	8.75	9.75	10.75	4.12
8.00	BT-80-1/10	BT-80-11/20	BT-80-21/30	BT-80-31/40	3.000	4.000	7.38	9.38	10.38	11.38	12.38	5.63

\* When BT-15-31/40 is required in aluminum material, the rod extension becomes 6.00